

TANK-860-QGW

Cloud Based IPC built-in with QTS Gateway OS for IIoT



• TANK-860-QGW-i5/8G/6A

VM, Container and Linux Station
three keys to opening virtual environments

- Built-in QTS Gateway operating system that can be visualized immediately
- Supports remote connection (myQNAPcloud) and hybrid backup (Hybrid Backup Sync)
- QRM+ easily monitors IPMI equipment, servers, PCs and production line equipment
- Q'center centralizes management of multiple QNAP NAS and the IPC equipped with QTS Gateway
- Surveillance Station for remote video surveillance, 24/7 security
- Seven levels of data security protection to protect your valued data



TANK-860-QGW-i5/8G/2A



TANK-860-QGW-i5/8G/4A



Table of Content

01	TANK-860-QGW – IPC + Cloud solution
03	Three-in-one virtualized application – computation, storage, network
10	Data center and backup – perfect integration of public and private clouds
12	Remote monitoring/Multi-server management – best helper for IT personnel
16	Data security – strict protection of corporate secrets
18	Surveillance Station – remote video surveillance
21	myQNAPcloud – breaking local area network restrictions for easy remote update
22	Creating your IIoT solution with QTS Gateway
24	Hardware specifications
25	Software specifications

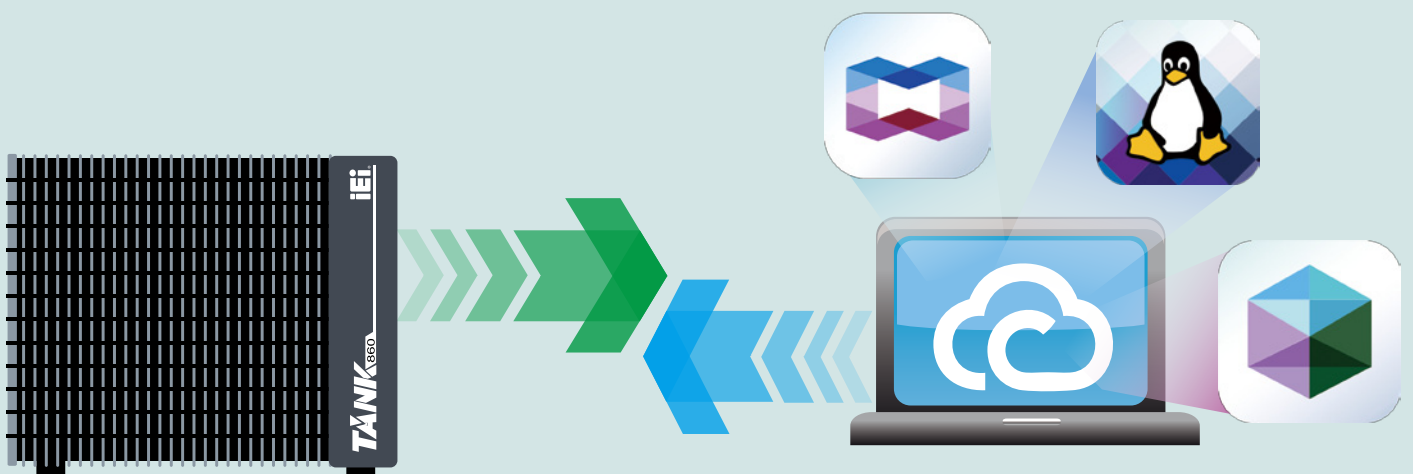

TANK-860-QGW – IPC + Cloud solution

IEI's new generation smart fan-less embedded computer has an ultra-rugged design that allows stable operation even under the worst environments; it is not only quiet but also safe. The TANK-860-QGW supports the QTS Gateway operating system allowing you to easily monitor the system status. Diverse application programs can also be downloaded to satisfy different application needs.

▶ QTS Gateway

QTS Gateway is an operating system designed specifically for IEI IPCs and fully integrated the QNAP NAS operating system (QTS), breaking through the stereotype of IPCs of not having operating systems and saving unnecessary costs for installing servers and computers. QTS Gateway not only allows easy monitoring of computer status through its visualized interface, it also allows the use of many free application programs, making it multifunctional while challenging the values of traditional IPCs.

	Traditional IPC	Cloud-based IPC
Remote System Visualization	No	Yes
OS	No (additional devices must be purchased and installed)	Built-in VM virtual application
Remote Device Management	No (additional management software must be installed)	Free software: Qcenter, QRM+
Data Backup	No (additional management software must be installed)	Hybrid Backup Sync
myQNAPcloud Management	No	Yes, supports system update through a cloud
Video Surveillance	No (additional surveillance software must be installed)	Free software: Surveillance Station
RAID Data Storage	No (must use with specific platforms)	RAID 0 · RAID 1
Support for Mobile Devices	No	Free App Qfile, Qmanager



Rich I/O interfaces, best control center

The TANK-860-QGW series has high-speed expandable PCIe and/or PCI slots and rich I/O interfaces, allowing users to use it as a control center. It is the best smart automation solution for you.

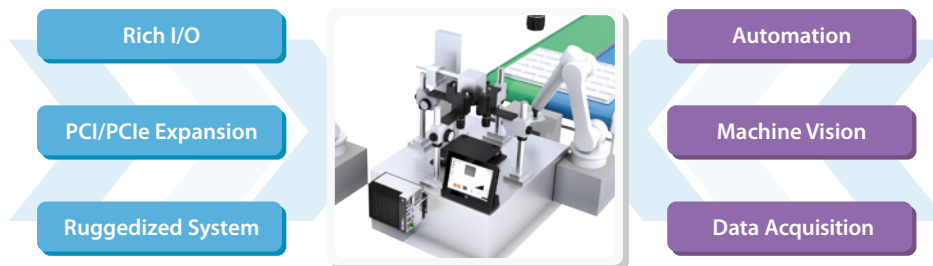

Dual 2.5" SATA easily expand storage capacity

TANK-860-QGW has two 2.5" SATA HDD/SSD bays that allow flexible capacity expansion, satisfying the need for large storage spaces. Dedicated data centers can be easily created with the use of cloud services, easy and convenient.

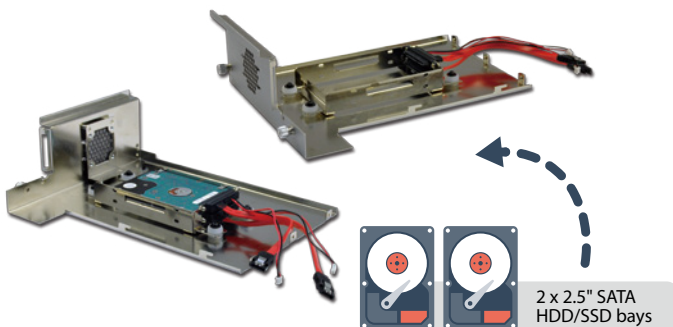

Hot-swappable CFast, enabling high-speed transmission at any time

Supports CFast storage cards providing transmission speed up to 300 MBps. It also has the hot-swap design that allows users to switch CFast storage cards while the system is still operating; data transfer can be easily completed without having to dismantle the machine.



Wide voltage design

The TANK-860-QGW series support wide-voltage DC power input, so all external 12V / 19V / 24V powers can be used.

Rugged shock-resistant, impact-resistant design

TANK-860-QGW is protected with a rugged case that allows it to resist strong shocks and vibrations and keep operating under rigorous industrial environments.

Multi-screen high-definition output

TANK-860-QGW includes VGA, DisplayPort and DVI video outputs that are applicable to application programs with multi-screen displays; it also supports HD video quality.

iRIS remote control technology realizing the IoT concept

TANK-860-QGW supports the iRIS-2400 module which can be installed to utilize the IoT concept to perform remote control functions, including power management/control, remote KVM monitoring or sending alarm and warning information through e-mail or SMS.



Heat and cold resistance, challenging rigorous environments.

TANK-860-QGW has a great cooling system that allows stable operation (with SSD) under -20°C to 60°C environments, suitable for use in factories, industrial and other rigorous working environments while providing secure network storage service.



Dual DC power input, double protection

TANK-860-QGW uses the dual DC power input design so that when one power is unusable or has low voltage, the system can still maintain operation through the other power input and prevent the risk of data loss due to sudden power lost.



Three-in-one virtualized application – computation, storage, network

The QTS Gateway fully satisfies virtualized application demands by providing two options for industrial IT personnel, including the full version Virtualization Station and the light version Container Station. The Linux Station released at the end of last year also brings IoT applications a secure and reliable cloud storage and secondary development/application solution.



Virtualization Station

Painless migration, complete OS virtualization

The virtual machine can share the network interface with TANK-860-QGW by defining the network through the software, and use internal communication to achieve best data transmission speed. The network operation mode is designed using the SDN structural concept; it supports Intel® VT-d (Virtualization Technology for Directed I/O) and allows external PCIe devices and RS-232 ports to connect (pass-through) to the virtual machine to provide high performance computing and transmission. No complicated relocations and settings are required from the physical machine to virtual machine to enjoy the same operation modes.

Quick transfer, zero threshold

There is no need to worry when replacing old machines with new ones because physical-to-virtual (P2V) technology can be used to create a familiar operating system (e.g. Windows XP, Server 2003) on the virtual machine. Existing services and data can also be moved to the virtual machine, adding more flexible system management.



Advances in VM network structure, again — the Software Defined Network

The past restrictions of VM taking up network ports for external-only networks and limited file transmission speeds can now be overcome. From now on, a dedicated 10 GbE LAN port for VM Ethernet is no longer needed. By adopting a Software Defined Networking approach, VMs can now share the network interface with TANK-860-QGW to maintain the best data transmission speed without being limited by hardware resources.

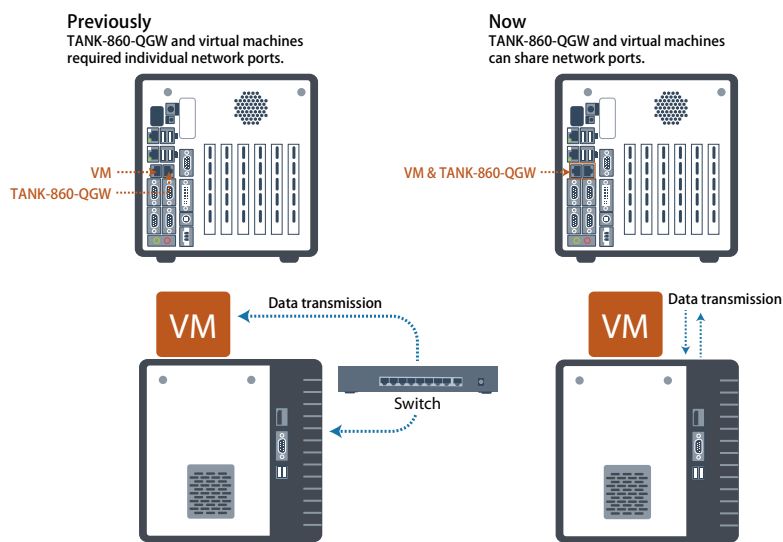

The architecture of SDN is mainly divided into application layer, control layer and infrastructure layer. At the application layer, the Virtualization Station is used to run and manage VMs. The VM orchestrator in the QTS operating system is used to receive a request from the Virtualization Station to manage workload schedules. When the Virtualization Station orchestrator receives a transmission request from the Hypervisor, the orchestrator will signal the vSwitch Controller (as the QNAP NAS's network control), and then the vSwitch Controller of the control layer will dynamically adjust the Hi-speed Virtual Switch so that VMs can connect with the Physical Networks or TANK-860-QGW storage for data communication.

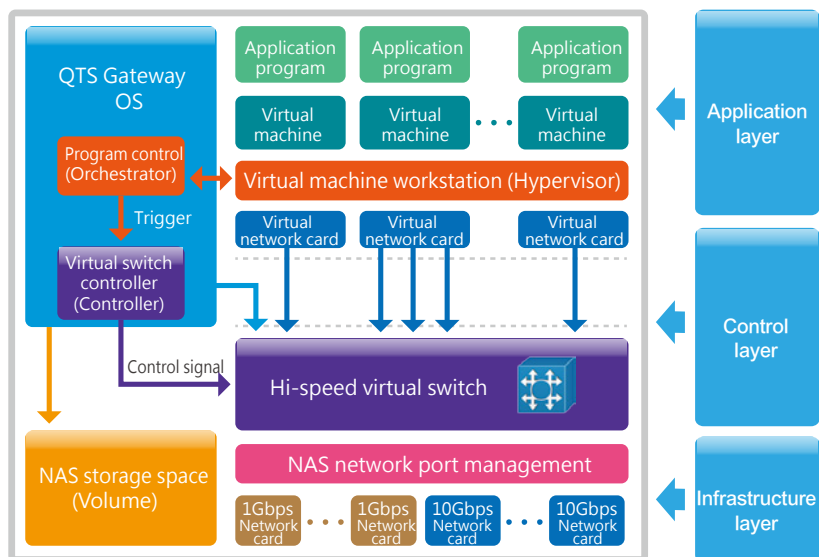

Virtual switch

Virtual Switch is the new network architecture employed by Virtual Station. Virtual Switches are an efficient and effective network design when compared to dedicated network ports. Virtual Switches enable VMs' to share Ethernet interfaces with TANK-860-QGW, removing the need for a dedicated VM network. Bypassing the need to transfer data through the physical network equipment also boosts the transfer rate between VMs and the TANK-860-QGW. The Virtual Switch is capable of 10 GbE and port-trunking, enabling you to obtain a fast and secure network environment.

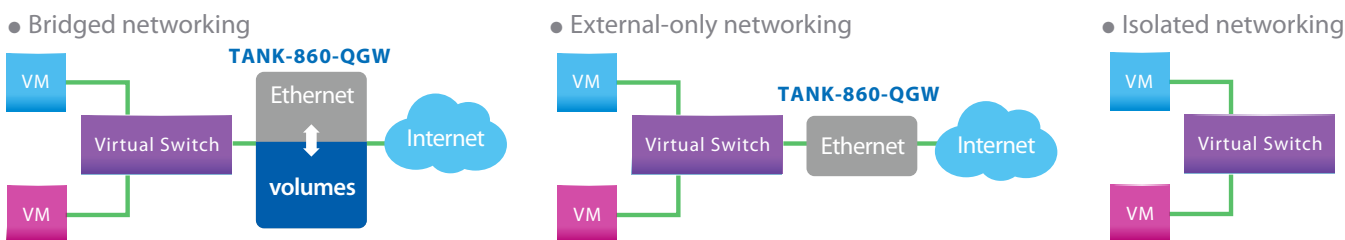

Bridged networking

Attaching an Ethernet interface (port-trunking available*) to a virtual switch creates a bridged network. The TANK-860-QGW and the Virtual Switch can share the same Ethernet interface without occupation and supports high-speed data transfer via internal routing, saving a 10GbE Ethernet port.

➤ Available port-trunking modes
Active Backup, IEEE 802.3ad, Balance-tlb.

External-only networking

After connecting a Virtual Switch to an Ethernet interface, this interface will be fully occupied by the Virtual Switch; all connected VMs can use this interface for external network transmissions. This networking mode may require manual setting of VM IP address or have the IP address assigned by the external DHCP server.

Isolated networking

Not attaching any Ethernet interface to a Virtual Switch creates an isolated network. Manually setting IP address of VMs can enable communication between VMs connected to the same Virtual Switch, but unable to communicate with TANK-860-QGW or external networks.

PCIe card connection

TANK-860-QGW adopts Intel® processor and leverages Intel® VT technology to run virtualized platforms, allowing VMs to use independent arithmetic units to provide secure computation environments (such as the ring-based privilege security of processors), and effectively divide computing resources so there's no need to worry about exceeding the allocated resources. In addition, a Virtualization Station can connect to PCIe devices through I/O pass-through, achieved by Intel® VT-d technology.

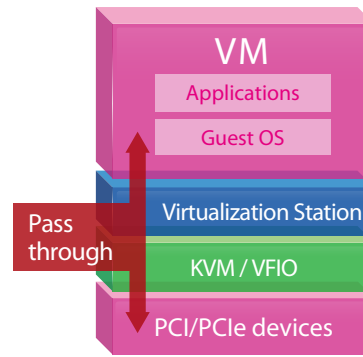

VM Backup & Restore

The task-oriented VM supports local and remote backup and restore, and a centralized easy-to-use management interface can be used to find out task progress and schedule in real-time; tasks can also be started or stopped manually. In response to the need for uninterrupted VM operations and services, the Virtualization Station supports online backup without having to power off the virtual machine. It can also save the snapshot record of the original VM so that you can restore to any recording point after restoring the VM. You can also set schedule for backup tasks and maximum number of backup copies in order to effectively utilize the storage space. When creating local restore tasks, it can start VM backup immediately in order to reduce the downtime while restoring.

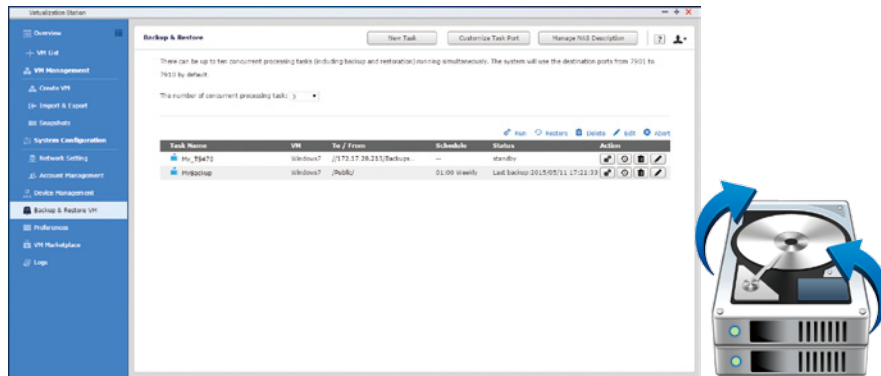

Device Management

The device management screen provides an overview of all VMs, keeping you informed of the storage capacity, networking interface and USB devices, as well as letting you connect or remove a new device.

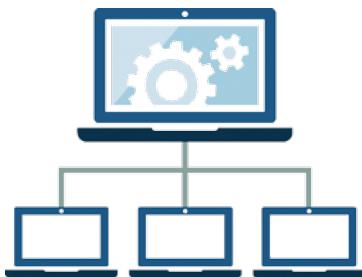

Remote Import & Export

Virtual machines of various formats can be easily imported to and exported from the Virtualization Station. IT administrators can get VMs up and running quickly on a Virtualization Station or other hypervisors.

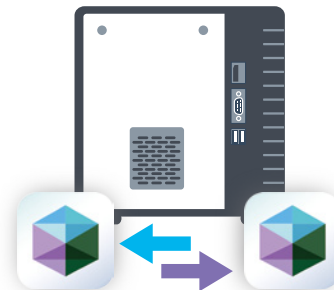

USB Passthrough

Virtualization station supports connecting external USB devices to virtual machines. Commonly used USB devices such as storage devices, card readers, USB key and commonly used USB devices in factory management such as USB sensing card readers and barcode scanners etc. can all be connected to the USB port of TANK-860-QGW, and you can select a specific device from the information page of the virtual machine to connect it to the virtual machine. By using it along with the QVM virtual desktop, not only does it save bandwidth, it is also as easy as operating an actual PC. Furthermore, with the advent of USB 3.0, higher data transmission can be easily achieved.

➤ Currently only supports Windows 8, Windows 8.1 or above.

Visibility and direct access to files

Downloading a large amount of data from the TANK-860-QGW to a local PC can take a long time and use up network bandwidth, or your device may not support specific formats and cannot be opened. Through virtual machine and application programs, files can be opened directly on the virtual machine, which saves time and avoids wasting bandwidth. When accessing files and data on a virtual machine they are not transmitted outside of the TANK-860-QGW. This eliminates the risk of hackers intercepting during file transmission and reduces the possibility of leaking sensitive data.

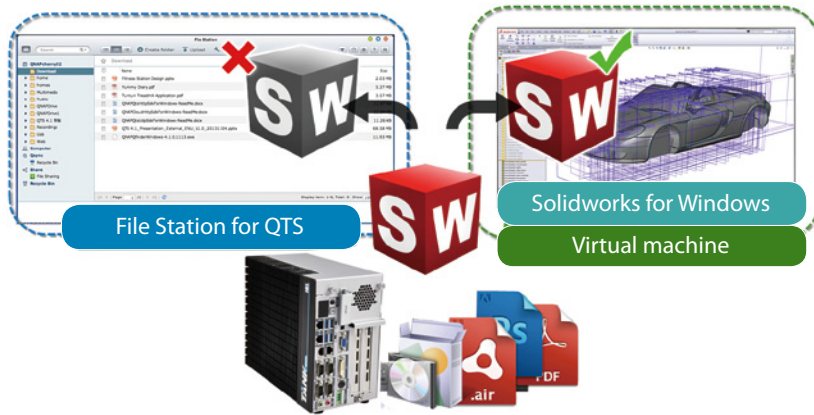

User-based permissions settings

The Virtualization Station administrator can create users and set granular permissions for each Virtual Machine (VM), helping to efficiently manage and allocate VM resources for users with different needs. With these permissions, users can work independently on their VM without worrying about their work being interrupted or data being lost because another user has accidentally powered-off the VM.

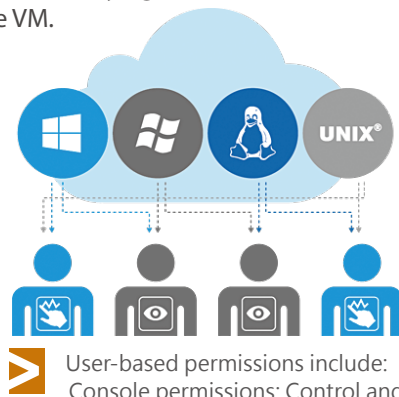

User-based permissions include:
Console permissions: Control and View-only VM controls: Snapshot and Advanced

Operate VMs through web browsers

You can install operating system on VM and then operate and manage the VM through web browsers. Function operations that can be performed include: suspend, shutdown, force shutdown, reset, bring up key combinations: Ctrl +Alt+ Del and on-screen keyboard, and take snapshots of the VMs.

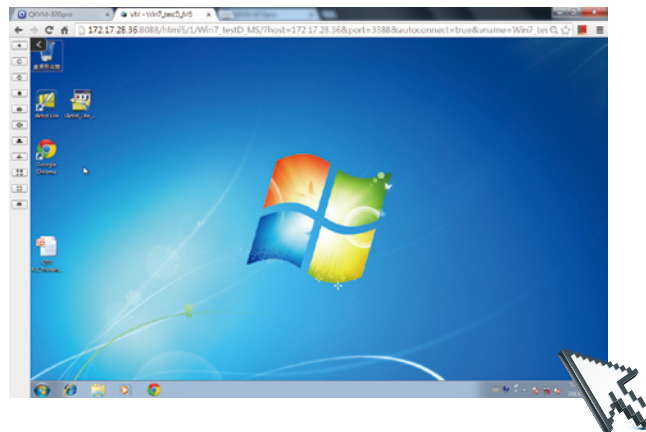



Container Station

Rapidly deploy containers

Container Station is developed following the Just enough OS, or JeOS, philosophy. This lightweight virtualization technology can instantly and truly create a ready-to-use environment on PCs, TANK-860-QGW and the Cloud for RD developers and IT administrators.

Micro services, quick deployment

Container Station only requires 64MB of memory to run an application program; such lightweight virtualization technology allows you to quickly deploy large numbers of environments.

Best partner for IoT maintenance and operation

Container Station supports the required device protocols (MQTT and AMQT etc.), interface services and data computation needed in the IoT environment, allowing it to be easily connected to the IoT era.

A growing number of popular apps

Container station offers the most up-to-date and top-of-technology applications for rapid deployment with just a click. The following apps are now available: LibreOffice, MongoDB, Nginx, Node.js, Redis, MySQL, WordPress, Deluge, Minecraft, Wine, Jenkins, GitLab, Redmine, Joomla! and OpenERP.



Integrate LXC and Docker® to bring even more value to your system

LXC: the lightweight Linux Container enables a high-performance lightweight virtualized Linux® environment on your NAS. Install a lightweight version of Linux® (e.g. Ubuntu, Debian, Fedora) as the base for your containerized application with LXC.

Docker® - quickly deploy large amounts of applications, achieving Docker lightweight microservices.



Install-on-demand applications

Use the Docker Hub Registry to search for official or third party applications, whether they are databases, web servers, programming languages or development tools; install it as you would install an app on your smartphone.

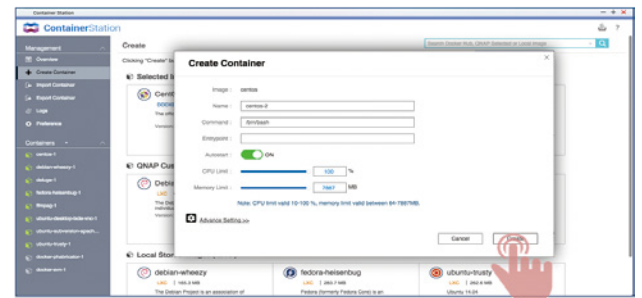

One-click installation

The Container Station installation wizard eliminates complicated setting processes and is able to automatically detect system configurations, helping you to easily complete one-click installation. Just click "Create" and enjoy the benefits of software containers.

Access shared folders

Shared folders mounted in a container (or from other containers) save data to the TANK-860-QGW at comparable access speeds to that of bare metal environment.

Export/import software containers

You can export software containers along with data contained in it to a given shared folder. You can also import software containers from a PC or shared folders. Containers can also be easily backed up and transferred to other QNAP NAS/TANK-860-QGW units.

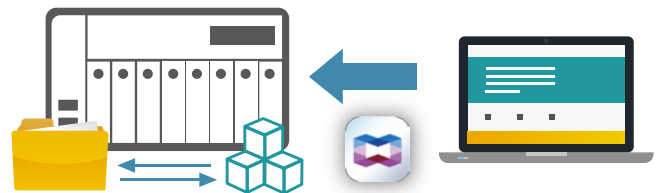

Resource management

Specify host CPU/memory resources allocated to a software container and monitor the host in addition to each container's performance from a single screen. The visualized presentation with graphics provides a quick overview of resource consumption and aids in resource management.



Online Document – Online document preview and editing

The increasing risk of breaches and leaks in recent years show that the spaces where files are saved have become the most important gateway for data security protection. With the Online Document application, you can easily view, edit and save files on TANK-860-QGW, including Office documents, images or text files. There is no longer the need to download the files to edit on a PC.

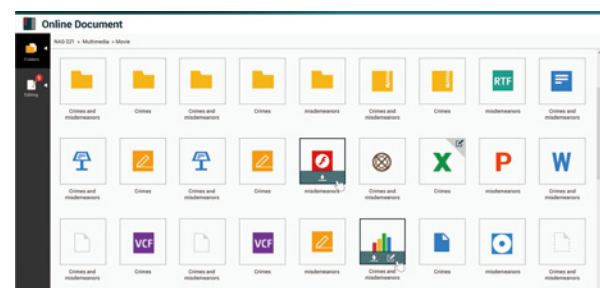

Supports a wide range of file types used by LibreOffice®, Pinta, Emacs, and more

- LibreOffice® - a powerful office suite: The suit has many applications: Writer (word processor), Calc (spreadsheet application), Impress (presentation engine), Draw (drawing and flowcharting application), Base (database and database frontend) and Math (mathematics editor).
- Pinta – a program for drawing and image editing: It offers a simple yet powerful way to draw images with formats such as JPEG/JPG, Tiff, TGA, PNG, ICO, BMP and Open Raster. It is surely more powerful than Windows Paint.
- Emacs – a customizable text editor: Emacs is a powerful text editor with extensibility and customizability. It is popular among programmers and computer technicians.

Easily establish a continuously integrated development environment

No need to memorize complicated software configurations, just use popular applications on Container Station along with one-click installation and the system will automatically finish the set-up process, quickly facilitating a development environment suited for collaboration.

 Recommended apps for quick installation: Private Registry, GitLab, Jenkins.

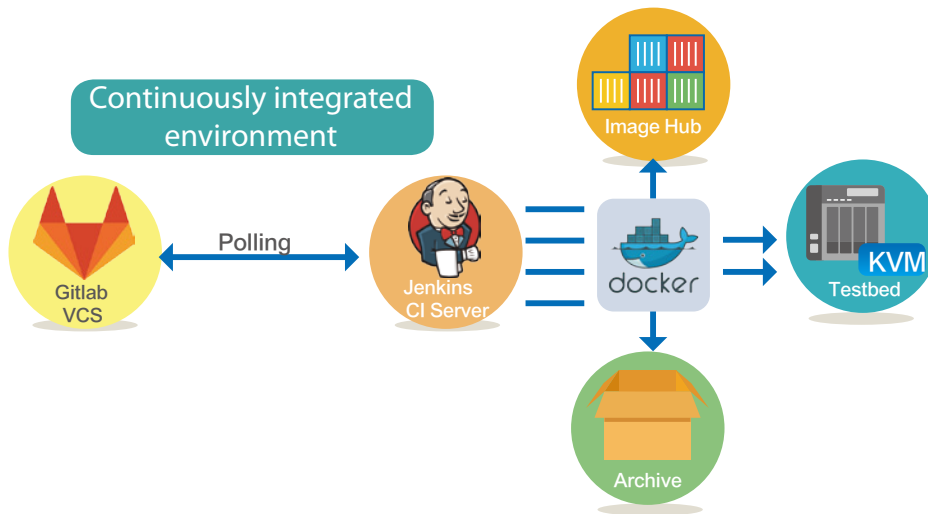

Linux Station

Creating an open source platform for unlimited potential

QNAP uses advanced virtualization technology to perfectly run both QTS and Linux operating systems in parallel. Just download Linux Station from the App Center and use VGA/DP/DVI display to output the entire Ubuntu desktop, and then add a keyboard and mouse to use the Ubuntu system just like operating a computer. Linux Station also allows you to freely switch between output resolutions and even enable the remote connection function so that the current outputted screen can be displayed through a browser at any time for remote controlling.



 Before using Linux Station, please first go to the App Center to install the Linux Station app. The remote desktop function currently does not support remote audio output.

Data center and backup – perfect integration of public and private clouds

In the era of information explosion, there are dozens of thousands of data being written every day. QTS Gateway continues the essence of the cloud purpose operating system and provides several management and backup tools to allow you to easily find data and back them up or share them to other devices or cloud services, providing more diverse and mind-easing backup management solutions.

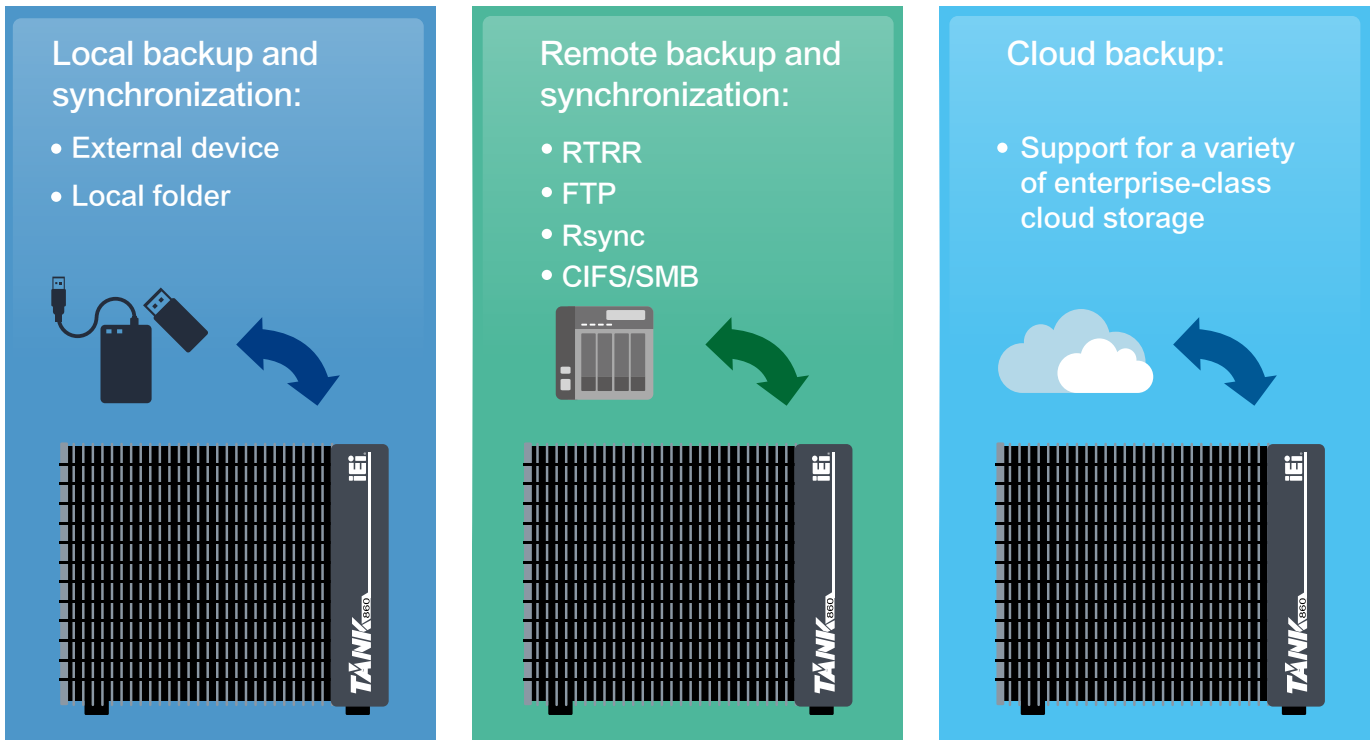

Local backup and synchronization

There is no need to connect to external networks; you can backup or synchronize data saved on TANK-860-QGW to local folders or external devices, leaving your mind at ease with dual protection.

Remote-site backup and synchronization

Your computer, NAS or TANK-860-QGW can also be a part in the complete backup solution. Data can be easily backed up from the workshop to NAS using QNAP RTRR (Real-Time Remote Replication) technology or Rsync. Data can also be synchronized to another computer through CIFS/SMB or FTP.

RTRR two-way shared folder backup and synchronization

RTRR enables saving backup files to time-based versions. In case of an incident, files can be restored to earlier backed-up versions specified by time and date. Smart versioning enables you to create backup versions hourly, daily, weekly or monthly to dynamically control the number of backups accordingly to your recovery objective. Alternatively, simple versioning keeps a fixed number of versions for a given period and automatically rotates stored versions. Use the RTRR service to set up real-time or scheduled synchronization of shared folders between two NAS units. With two-way synchronization, file backup consistency is improved and is especially helpful in synchronization and collaboration across departments and branch offices.

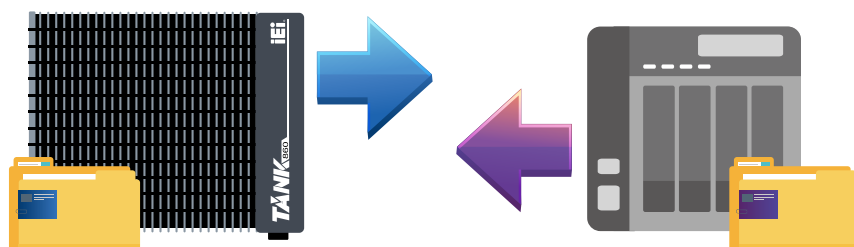



Hybrid Backup Sync

Centralized file storage and management

Hybrid Backup Sync is a comprehensive backup solution to efficiently manage storage space for all devices on the LAN, across remote-site NAS units and cloud services by checking the amount of free/used storage space, achieving flexible utilization of storage space. You can also create a remote connection account to record and encrypt all remote connections to accelerate remote-site or cloud backup jobs.

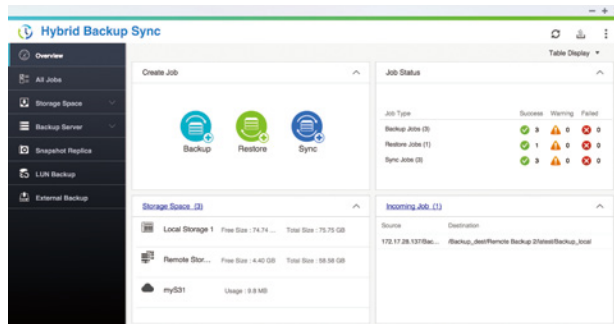

Cloud synchronization solution

Hybrid Backup Sync supports major cloud storage services and synchronization with designated folders. The Hybrid Backup Sync supports Amazon® Cloud Drive, Google™ Drive, Dropbox™, Microsoft® OneDrive®, Yandex.Disk, Box and more for continuous synchronization between your TANK-860-QGW and cloud storage.

➤ OneDrive for Business and hubiC cloud synchronization services will soon be released.

Cloud backup made simple

QNAP integrates cloud services for users to back up their data to cloud storage spaces in real-time or by schedule, including Amazon® S3, Amazon® Glacier, Microsoft® Azure, Google® Cloud Storage, and others compatible to S3, OpenStack Swift, and WebDAV. Data can also be restored to the TANK-860-QGW when disasters occur so that you can create simple and affordable disaster recovery plans to help you recover files when disasters actually happen.

1 Compress

Hybrid Backup Sync supports compressed backup files, scheduled file deletion according to users' specifications and sparse file detection to avoid backing up unnecessary files. You can screen files by type, size, and date to ensure only the required files are saved on the cloud for greater storage and cost efficiencies.

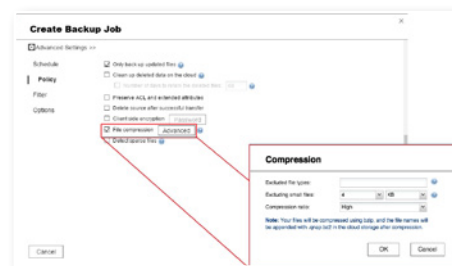

2 Select folder and encrypt

Hybrid Backup Sync features an SSL-secured connection and military grade AES 256-bit data encryption to protect your data in transmission and at rest on the cloud.

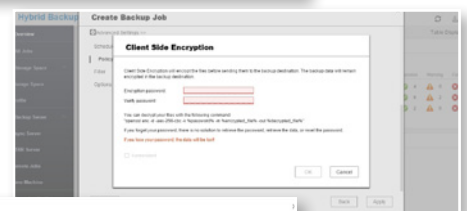

3 Multi-thread transmission

Hybrid Backup Sync supports multi-task processing and multi-threaded data transfer*. The latter improves files transmission speed and enhances work efficiency by segmenting large files into smaller ones before uploading. You can preview files in the cloud and download individual files instead of the entire folder.

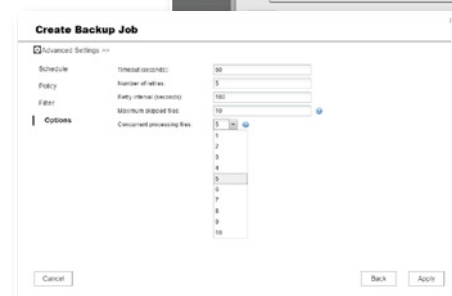

➤ WebDAV App does not support multi-threaded data transfer.



Remote monitoring/Multi-server management best helper for IT personnel

QTS Gateway provides several productivity tools, allowing IT personnel to use visualized charts to manage and monitor the IPMI server or other devices with the QTS operating system installed, lowering related fees for management and maintenance and maximizing information management and productivity of the staff.



QRM+ IT infrastructure management

QRM+ is a centralized remote server and PC management solution from QNAP designed for IT teams. QRM+ monitors and controls the pulse/health of all the mission critical servers in your network. QRM+ provides a single point solution to discover, map, monitor and control all the critical devices (Servers/PCs/Thin Clients etc.) in your network. Manage your servers remotely from different client with-in or from outside of the same network.

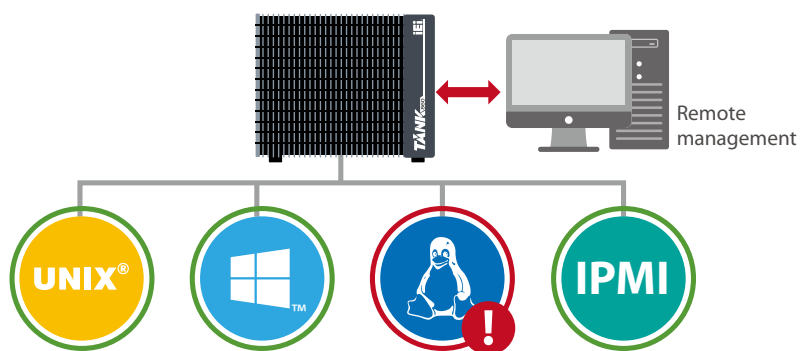

- Improve server health status control for the administrators
- Discover, map, monitor and control resources in your network on a single platform.
- Supports Agent based (QRMAgent) and Agentless (IPMI) surveillance, supports IPMI 2.0.
- Keeps track of all mission-critical device settings and provides state of art alert/event management.
- Generate reports to help analyze the performance of network resources.
- Exclusive QRMAgent (lightweight remote management agent service) that supports multiple platforms such as Windows and Linux.
- Save time on troubleshooting and quickly restore the system to operable status.



Discover



Map



Monitor

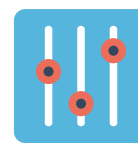

Control



QRMAgent

Developed by QNAP, QRMAgent is an agent program installed on workstations. QRM+ can monitor and manage the workstations through this program. After you add a device to the QRM+ server, the system will automatically install this agent program to that device. Or, you can choose to manually install QRMAgent on the workstation if you prefer. QRMAgent currently supports the following operating systems (more to be added later):

Platform	Operating System
x86 - Windows	Windows XP/7/Vista/8/8.1/10, Windows Server 2008/2012
AMD64 - Windows	Windows XP/7/Vista/8/8.1/10, Windows Server 2008/2012
X86 - Linux	Ubuntu 12.x/14.x/15.x

Customizable dashboards

You can use the QRM+ dashboard and the provided graphics and reports to monitor all devices and settings. You can also customize the dashboard according to your preferences. Multiple graphic and informative widgets make system monitoring simple.

Device discovery and topology

QRM+ identifies all the devices on your network including routers, switches or other devices. Discover all the devices on your network using an IP range scan. QRM+ maps discovered devices into a network topology. You can also personalize this network topology. Network topology is a powerful tool to quickly provide an overview of the network environment and assist you in visualizing your networks and quickly isolating the root cause of a problem.

Web-based management

QRM+ is a centralized, web-based solution accessible to your IT administrators from any web browser. QRM+ supports monitoring multiple components in your system, including CPU, memory and disk utilization, CPU temperature, CPU fan speed, and many more. This gives complete visibility of all system operation statuses. The most advanced alarm and event notifications help the IT staff to set and receive alarm messages about different system parameters. This can notify administrators in advance before an incident occurs.

Remote KVM solution for IPMI

The QNAP proprietary KVM Proxy solution for IPMI compatible servers enables you to remotely control a server even if the server is turned off or in BIOS mode. QRM+ KVM solution supports multichannel access enabling more than one critical client to connect to the remote server using KVM at the same time. QRM+ supports remote desktop for non-IPMI devices based on noVNC technology.

Remote KVM recording and playback

Enable KVM recording and all the KVM data will be recorded in video format to the TANK-860-QGW. This enables playback of the recording based on date and time to track specific events. This provides a unique way for users to log each action taken on the server and improve security.

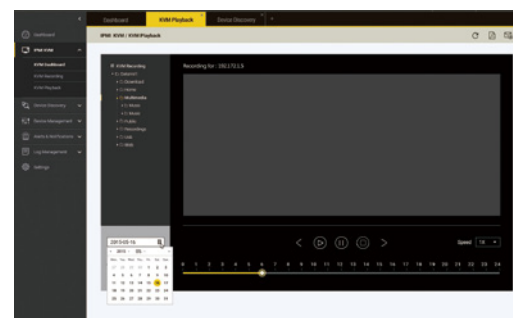
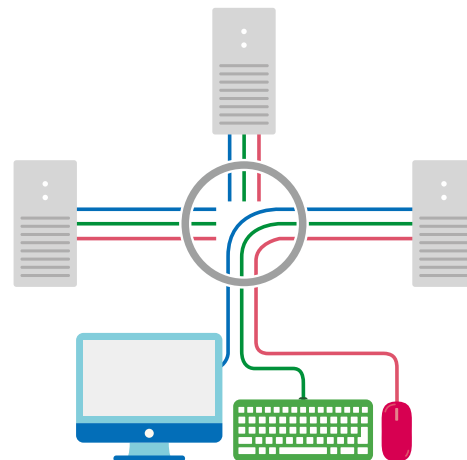
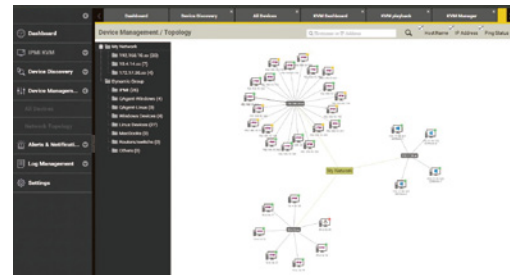
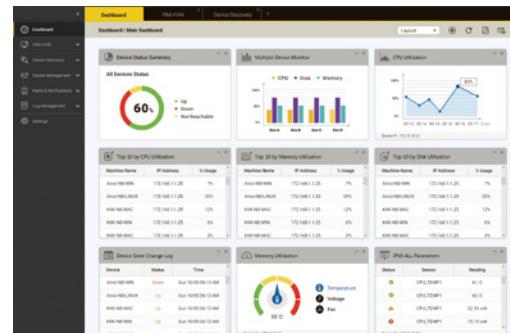



Q'center

Centralized multi-NAS management

Q'center is a powerful management tool integrated in QTS Gateway. You can view the status and system information of multiple NAS and TANK-860-QGW units at the same time from the Q'center Server. You only need to install Q'center on a TANK-860-QGW or NAS, and all their relevant system information can be easily checked on the Q'center Server. Q'center can greatly assist IT administrators in system resource allocation and future capacity planning.

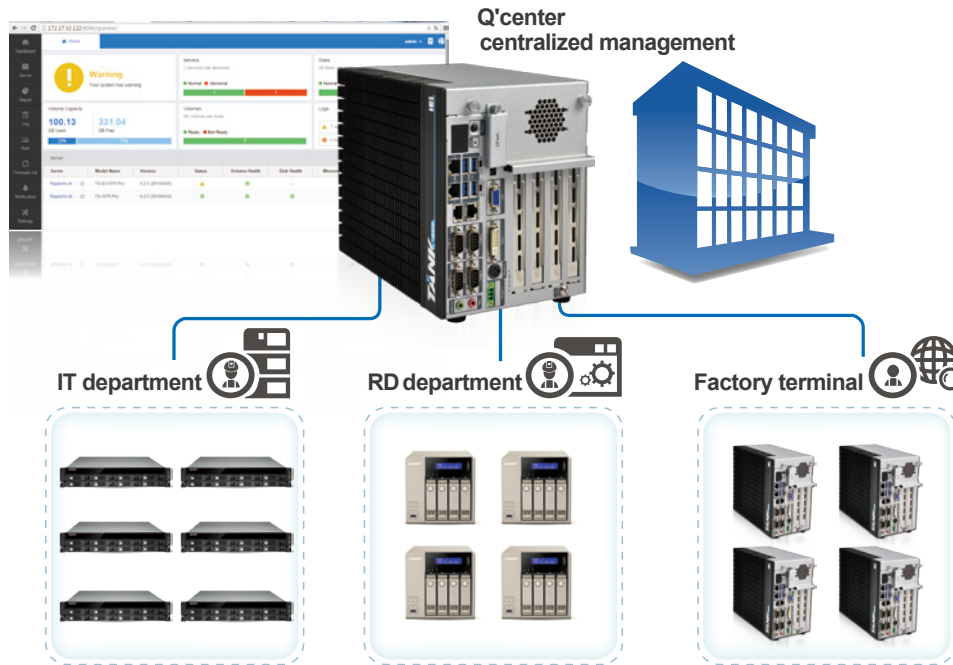

Informative customizable dashboards and equipment status indicators

Besides static reports, Q'center also features a customizable dashboard that allows you to rapidly view the system status of all QNAP NAS and check relevant operations logs. If you prefer to keep yourself always updated about the monitored devices, you can also set the advanced notification features on Q'center for key system indicators, such as storage capacity, hardware resources, or bandwidth usage. Then, as soon as Q'center detects any device abnormality, the system will directly notify you with a real-time message.

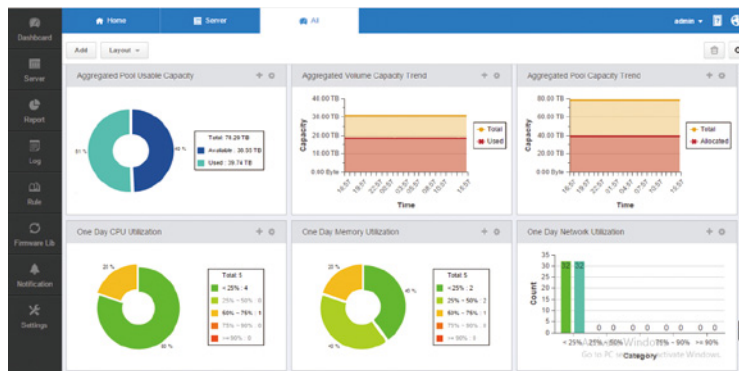

Concurrent large-scale deployment

Besides monitoring and recording, Q'center can also simplify the process for system, domain and network service setup when you deploy a large quantity of QNAP NAS / TANK-860-QGW. Q'center's advanced features (for example, regular backup, instantly restore system settings, centralized installation or updating of applications and one-time update firmware on all devices etc.) also allow you to improve efficiency in managing a large number of storage devices at your datacenter.



NAT technology for complex network environments

You can install the Q'center Assistant QPKG on the NAS that you want to manage and set it up to connect with Q'center. This design allows Q'center to be deployed in all types of network environment and ensures a constantly connection between the Q'center server and all clients with its firewall traversal technology.



Flexible and convenient virtualization application

To simplify your management routines, QNAP provides a virtualized version of Q'center for running it in a virtual machine within a VMware or Windows Hyper-V environment*. This version is available for all QNAP NAS models and you can directly deploy it on the server that is used to monitor all IT devices. This makes Q'center a more flexible and monitoring-efficient choice for IT personnel to manage all QNAP NAS



Supported platforms: VMware ESXi server ESXi 5.0, ESXi 5.1, ESXi 5.5, VMware Fusion 7, VMware Workstation 11 and Microsoft Windows Server 2012 R2 with Hyper-V 3.0.

Data security – strict protection of corporate secrets

The risk of data security has emerged recently. When using TANK-860-QGW as a data storage center, strict protection is required especially for confidential business files and machine data etc. In view of this, QTS Gateway provides comprehensive protection to help you protect your data and lower security risks so that the IT staff can focus on system applications.

Network environment configuration

TANK-860-QGW provides two network ports; different application services can be used with each port to manage the network, achieving secure deployment and segmented management. In addition, Port Trunking – Link aggregation can combine the two network interfaces into one and breakthrough the maximum load value of a single interface; not only can this provide high performance file transmission, it can also adjust the load balancing. Or create black and white lists to filter suspicious IP sources in order to achieve the goal of connection security.

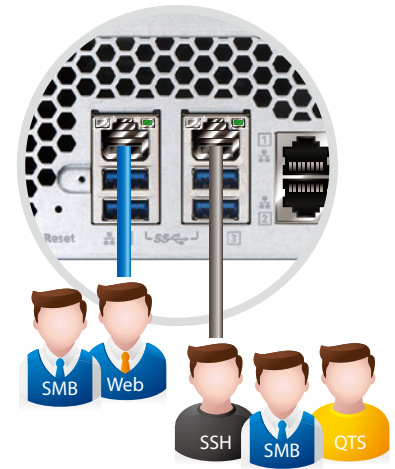

Account security (Two-Step Verification)

The Two-Step Verification* requires user to log in with both a password and a 6-digit one-time password (OTP) generated by an authenticator app. To simplify the log in process, trusted devices (e.g. home computer) can be "remembered" and only the password will be required from future log in attempts from that device.



 An authentication program needs to be installed onto your mobile device. For example, Google Authenticator (Android, iOS, BlackBerry) or Authenticator (Windows Phone).

Transmission encryption

QTS Gateway supports SSL and SSH encrypted transmission and connection. It also supports SFTP to increase the security for accessing and transmitting files. In addition, you can also set TANK-860-QGW as a VPN server/client to create secure network channels, or download the QNAP Proxy Server kit to set TANK-860-QGW as a proxy server to increase network speed and security.

Data encryption

TANK-860-QGW supports many types of encryption functions so that disk volumes, folders and even external hard drives can be encrypted, providing strict protection for data security and prevent them from being stolen by interested parties.

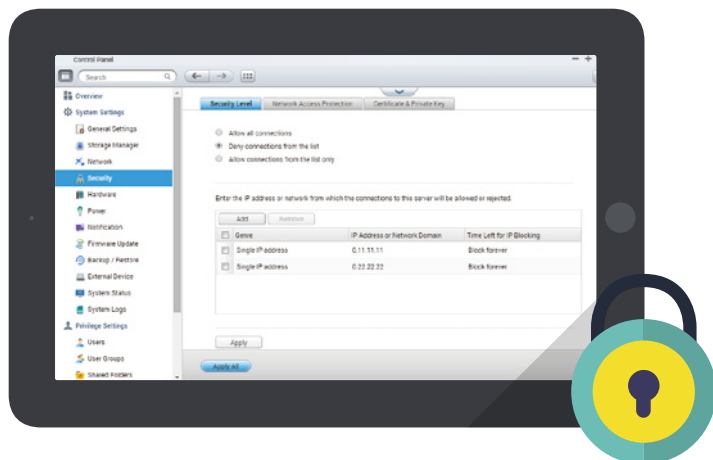

Anti-Virus protection

QTS integrates the ClamAV™ antivirus toolkit to defend against the latest viruses, malware, worms, and Trojan horses with continuous free virus database updates, ensuring continuous business operation. QTS also supports McAfee™ virus scanner (which is available in the QTS App Center with a free 30-day trial).

RAID (RAID 1)

Using large capacity hard disks with TANK-860-QGW makes it your best file management center. No longer worry about damaging data on your portable hard drive due to collisions. RAID 1 backup mode allows data to be restored simply by replacing a hard drive when your hard drive is damaged*. There is no longer the need to spend lots of money on recovering data.

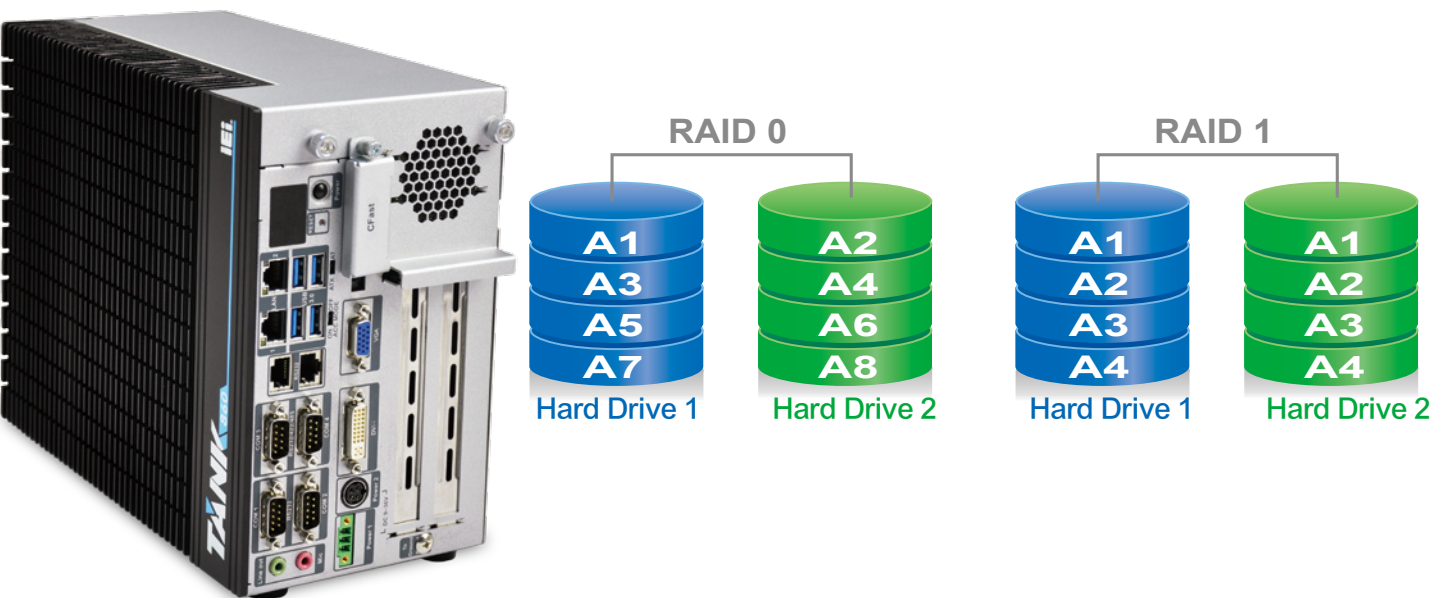

Local/remote snapshot

QNAP's full system Volume / LUN snapshot technology uses Copy on Write to record the usage status of the current file. When something goes wrong with the system, the snapshot technology can be used to quickly restore the files to their normal status. You can also use the snapshot synchronization function in Hybrid Backup Sync to snapshot and backup the disk volume to remote servers in order to create a complete backup protection network.

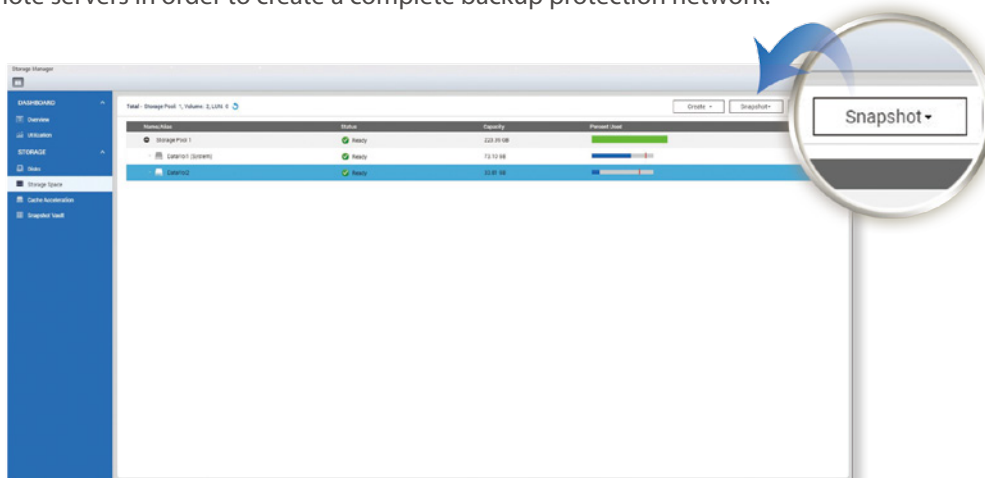

Surveillance Station – remote video surveillance

QNAP video surveillance center provides four free camera channels, and supports ONVIF and PSIA universal camera protocols, compatible with over 3,000 IP camera models of over 100 brands. It allows you to easily create an automated video surveillance system for your factory to protect property and personnel safety, and to create a working environment with no blind spots.

free 4 video channels

- Real-time monitoring
- Quick playback
- HDMI output
- Remote copying and storage expansion
- Supports monitoring of dedicated hard drives
- Supports ONVIF and quick installation interface
- Mobile and Vcam
- Odewarp fisheye recovery

Network load balancing, achieve the best hardware performance

Empowered with a tiered storage architecture, QTS can now separately store data in different storage pools that consist of dedicated hard drives. Additionally, you can designate dedicated network ports for NVR or NAS traffic to achieve the best data write/read performance.

Find out about surveillance status at any time

You can upload the floor plan to the video surveillance center and then drag the webcam icon to the installed positions. Once an alarm event occurs, the camera icon will flash allowing you to quickly check and resolve the situation. You can also set five e-mail addresses for the system to send alarm event notification.

Enabled	Status	Share Folder	Recording Time Period	Days Recorded	Create Time	Action	
<input type="checkbox"/>	True	normal	*/25/26/27/12	0	2015/07/24	[X]	
<input type="checkbox"/>	True	normal	*/28/29/30/1/0	0	2015/07/24	[X]	
<input checked="" type="checkbox"/>	True	normal	*/25/26/27/Recording	2014/01/08-2014/02/19	7	2015/07/20	[X]
<input type="checkbox"/>	True	normal	*/25/26/27/1/0/1	0	2015/08/03	[X]	
<input type="checkbox"/>	True	normal	*/28/29/30/1/3	0	2015/08/04	[X]	

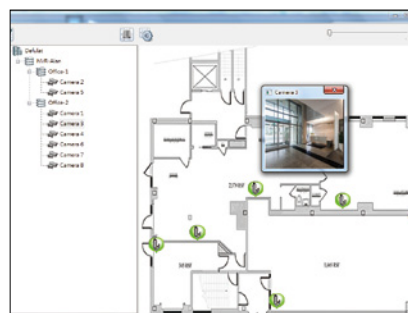

Quickly build a professional surveillance system in 3 easy steps

1 Select where to save Surveillance Station recordings

During the initial setup of Surveillance Station, designate a location to save Surveillance Station recordings. QNAP advises a dedicated storage pool for recordings.

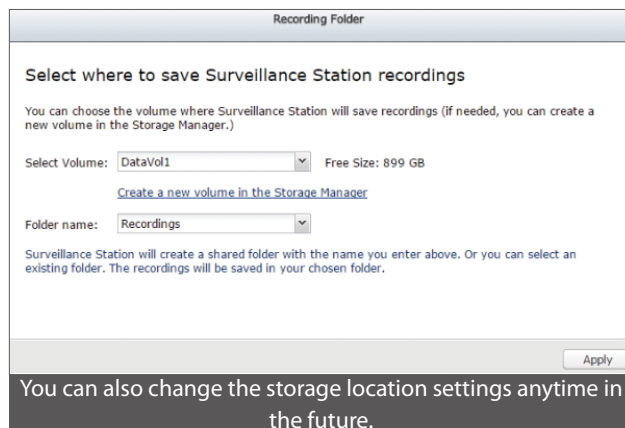

You can also change the storage location settings anytime in the future.

2 Set up the cameras

Complete the camera installation and confirm that the cameras are on the same LAN as TANK-860-QGW, click "Add" and Surveillance Station will search for available cameras.

In addition to IP cameras, USB cameras are supported by installing the QUSBCam2 app from the App Center.

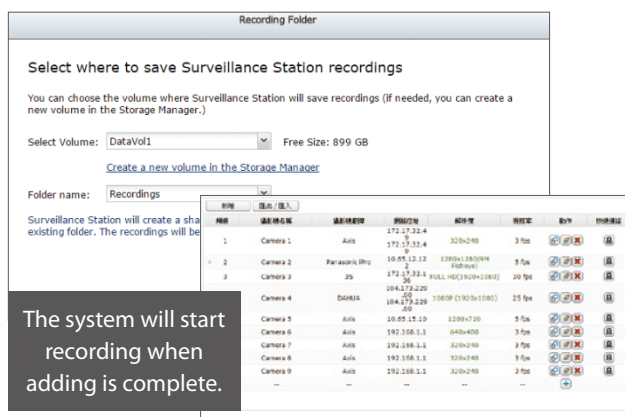

3 Start monitoring or playback

There are several ways to playback recordings or to monitor cameras with the Surveillance Station. Click "Playback" or "Monitor" in surveillance system, or use the Vmobile app or QvPC to monitor the camera feeds.

If you are using a PC or Mac, please install the client utility first. Click "Monitor" or "Playback" and the wizard will show up to guide you through the installation process. Clients are able to log into different surveillance stations to monitor their subset of cameras.

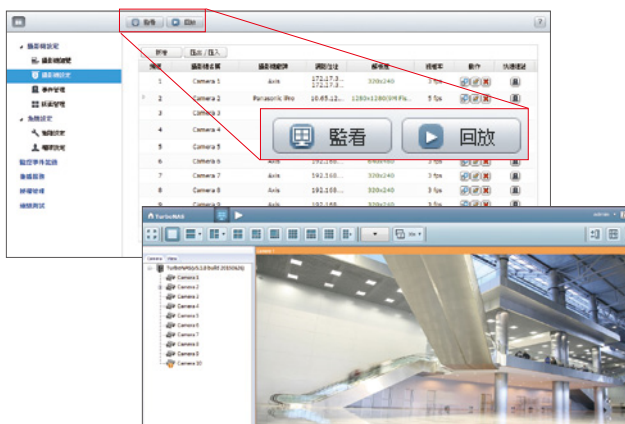

Automatically configuration updating

Surveillance Station 5.1 with a double video space usage threshold default settings, will not let you save images remaining space is less than 5%, or image space than 1TB. If you construct more than 1TB hard disk space for image storage monitoring, it is recommended to adjust the video size of the space and you can use the larger storage space.

Threshold values can be adjusted on-the-fly.

Upper and lower storage limits for fine-tuned administrative control

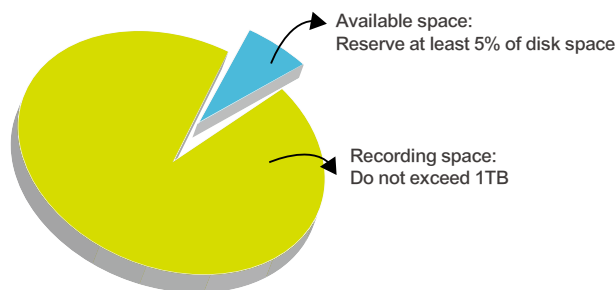

Diverse layout choices for playback and monitoring

QNAP supports various monitoring modes to display 1, 2, 3, 4, 6, 8, 9, 10, 12, 16, 20, 25, 36, 49, and 64 channels on a single screen. If these standard modes cannot satisfy your monitoring application, you can also customize the layout you need from the layout management function.

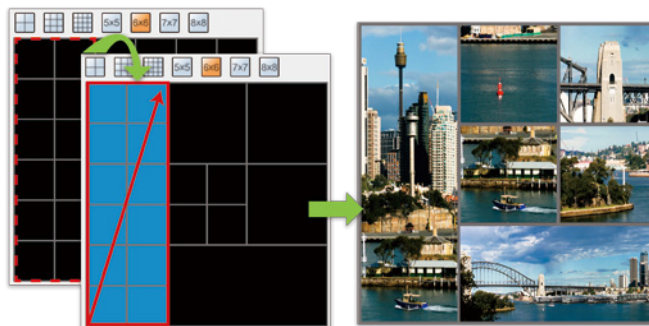

Playback speed control with the shuttle bar

With the speed-control shuttle bar, users are able to fast forward and rewind playback by dragging the bar to find the desired capture quickly; you can also control the speed. When you get close to the time the event occurred, you can view frame by frame to check details on the event.



Virtual camera

Very high-resolution cameras often lose details in playback display of huge coverage areas, presenting a problem for surveillance users. Using virtual camera technology, users are able to focus on defined sub-areas within the area captured. Virtual cameras do not require additional licenses, making them ideal for deployment in areas requiring expansive coverage.

PTZ Control and ROI

Directly adjust the vertical tilt, left/right panning angles, and zoom on cameras with compatible PTZ (Pan/Tilt/Zoom) functions. The "Click Go" PTZ control feature greatly enhances the convenience of remote surveillance. The ROI function is excellent for high definition cameras and enables users to freely enlarge, adjust, or move the region of interest on any recording channel. Surveillance Station 5.1 retains ROI settings for each session so it is ready at the next log in.



 QNAP Surveillance Station 5.1 supports digital watermarking to assist in verifying the authenticity of exported videos and snapshots by showing the exact recording date & time, camera name, and model name.

QNAP Qdewarp

Fisheye lenses are ideal for wide-angle scenes, but its disadvantage is that the edges of the images will be distorted. With dewarping technology, users are able to view detailed images without distortion. Qdewarp is compatible with every fisheye camera that QNAP supports, and you can select the type you want to view from a layout of various de-warping images; you can also move the area to de-warp at any time. Qdewarp supports real-time monitoring as well as recording playback, ensuring there are no blind spots.

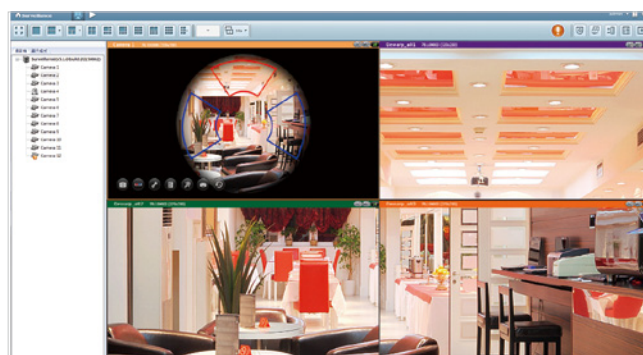

myQNAPcloud – breaking local area network restrictions for easy remote update

myQNAPcloud service provides solutions for remote connection, including DDNS, automatic router redirecting and CloudLink etc., eliminating complicated network and router settings and allowing you to connect and check the status of TANK-860-QGW as well as to update the system even when you are not on the same local area network. Device and network settings can no longer stop you from enjoying the benefits of cloud service.



SSL secure connection credentials

QNAP provides optional purchase of myQNAPcloud SSL credentials so that secure transmission channels can be created between the browser and the TANK-860-QGW to ensure data security.



Qmanager
Remote manage/ monitor

You can use Qmanager to remotely check system connection records and statuses, and even set push notifications to allow TANK-860-QGW to send you real-time notifications when specific events occurred and find out the latest system status.



Qfile
Remote file access

Qfile allows you to remotely access the data on TANK-860-QGW; several types of file formats can be browsed and shared with other people through e-mail or application programs. Compressed files can also be created to prevent the files from being too big and all of these can be completed using a mobile phone!

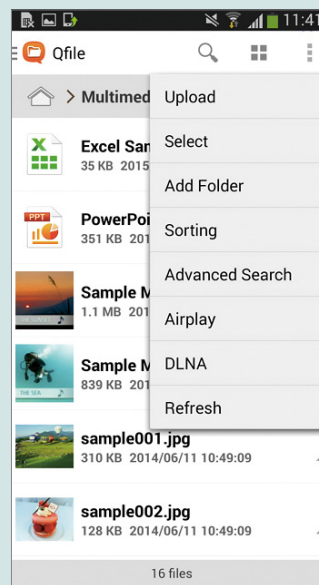
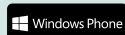
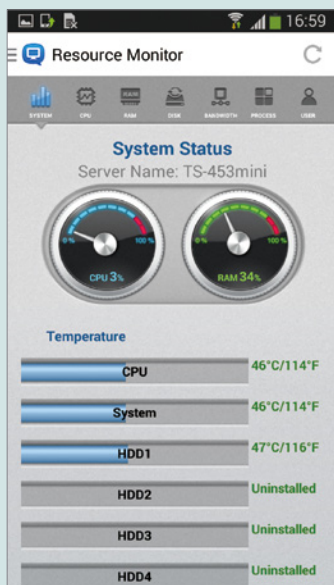

Creating your IIoT solution with QTS Gateway

The IIoT (Industrial Internet of Things) concept is changing the past production modes; more and more automated equipment is used to replace manual labor. However, the meaning of automation would have been lost if these equipment still have to rely on a lot of manpower. Machine to machine (M2M) communication, data storage and analysis capability are the keys to creating a smart production line. IEI incorporates with QNAP to launch its TANK-860-QGW cloud-based IPC with QTS Gateway operating system, offering possibilities of connecting devices, communications and the cloud servers for IPC applications.

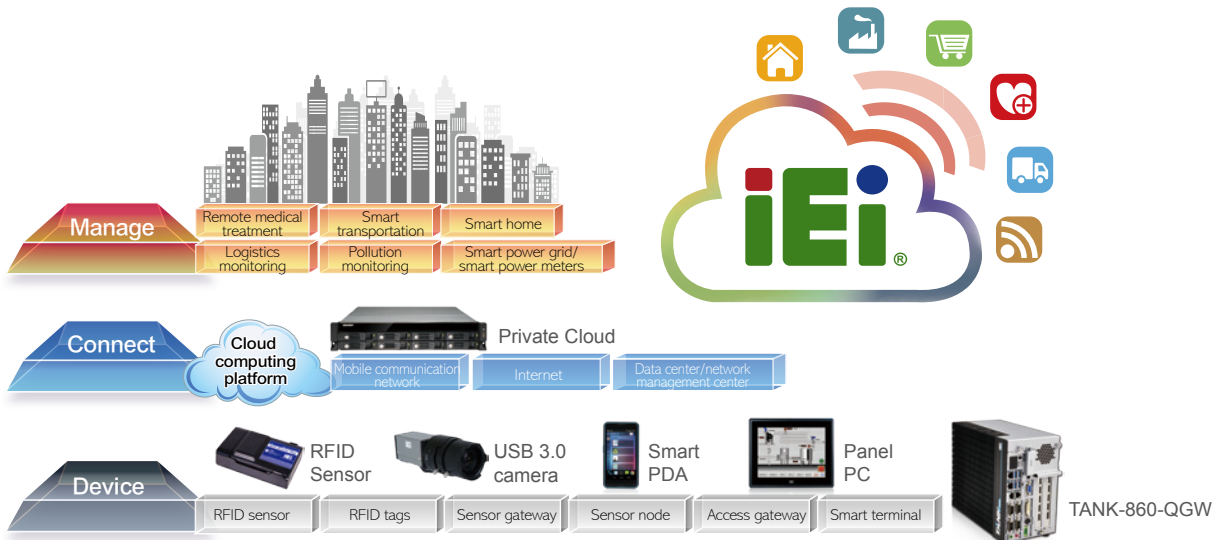

Application example 1: Big data analysis, fast and accurate Auto ID

Many companies use automatic identification (Auto ID) technology to keep track of the locations of materials and goods, and the production statuses, but the speed and accuracy are never very satisfying. TANK-860-QGW can connect with barcode readers to collect data which can be sent to the machines and alarm systems on the production line in real-time by running barcode reading programs on VM through Virtualization Station, achieving M2M communication. In addition, original data and the analyzed data can be sent to the IDC or the R&D staffs through Hybrid Backup Sync to use as a basis to optimize the system and capacity.

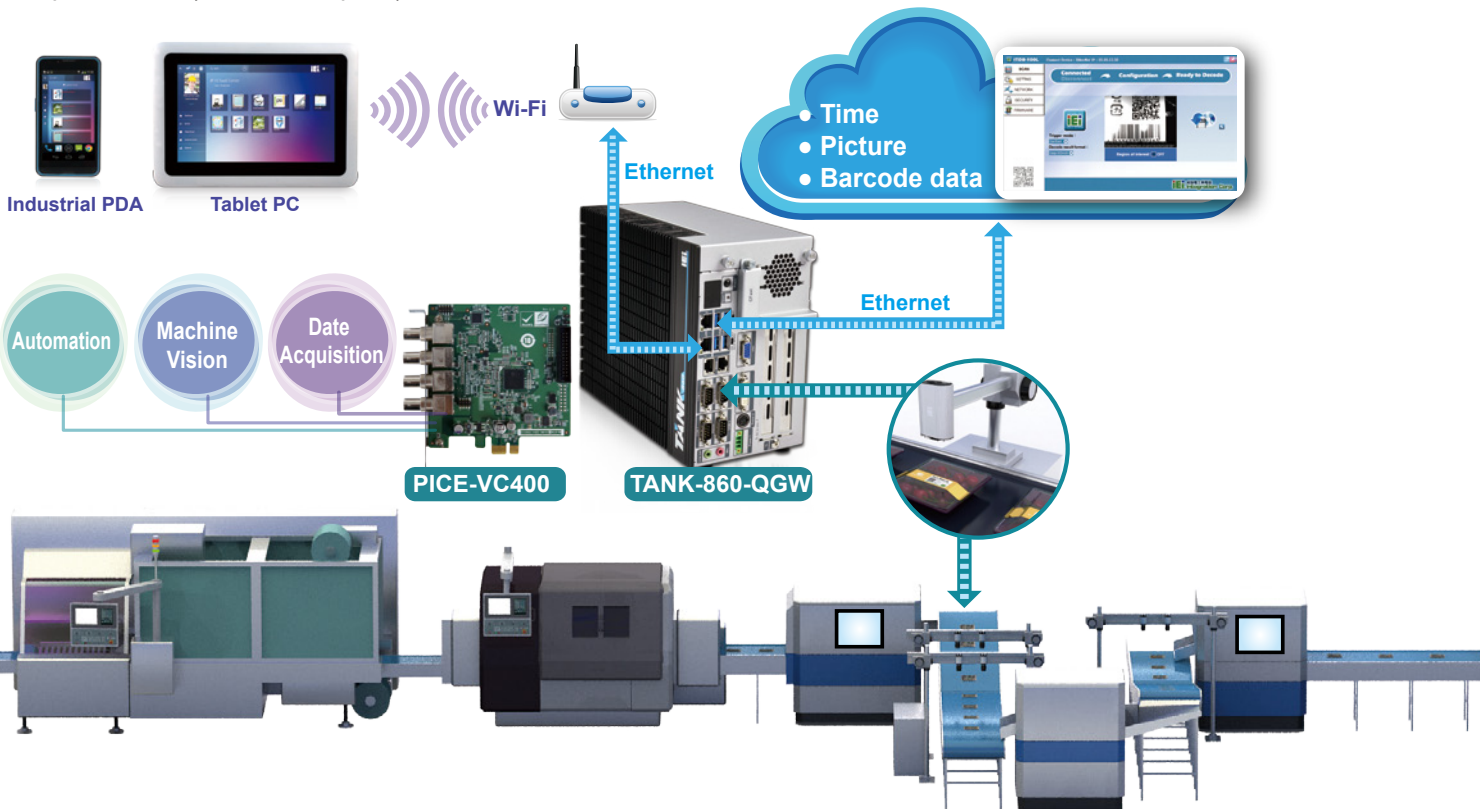

Application example 2: Central nervous system of robots

TANK-860-QGW is like the brain of robots and its multiple I/O outputs can connect to various automated control, machine vision and data acquisition devices, just like the limbs and sense of human. The PCI-SN300 motion control card can be controlled by running application program on VM using Virtualization Station, allowing USB 3.0 cameras to capture images to use as the eyes of the robot to perform positioning. Robots can exchange data and use algorithms to optimize application programs, and then send it back to TANK-860-QGW to send unified commands to all equipment. In addition, Hybrid Backup Sync can also be used to backup data on to other storage devices, lowering the risk of data loss and preserve precious data.

Connectable devices:

VGA, DisplayPort, DVI: display screen

RS-232/422/485: PLC

DIO: Supports DIO equipment, switch and alarm

USB : Supports USB 2.0 and USB 3.0 devices

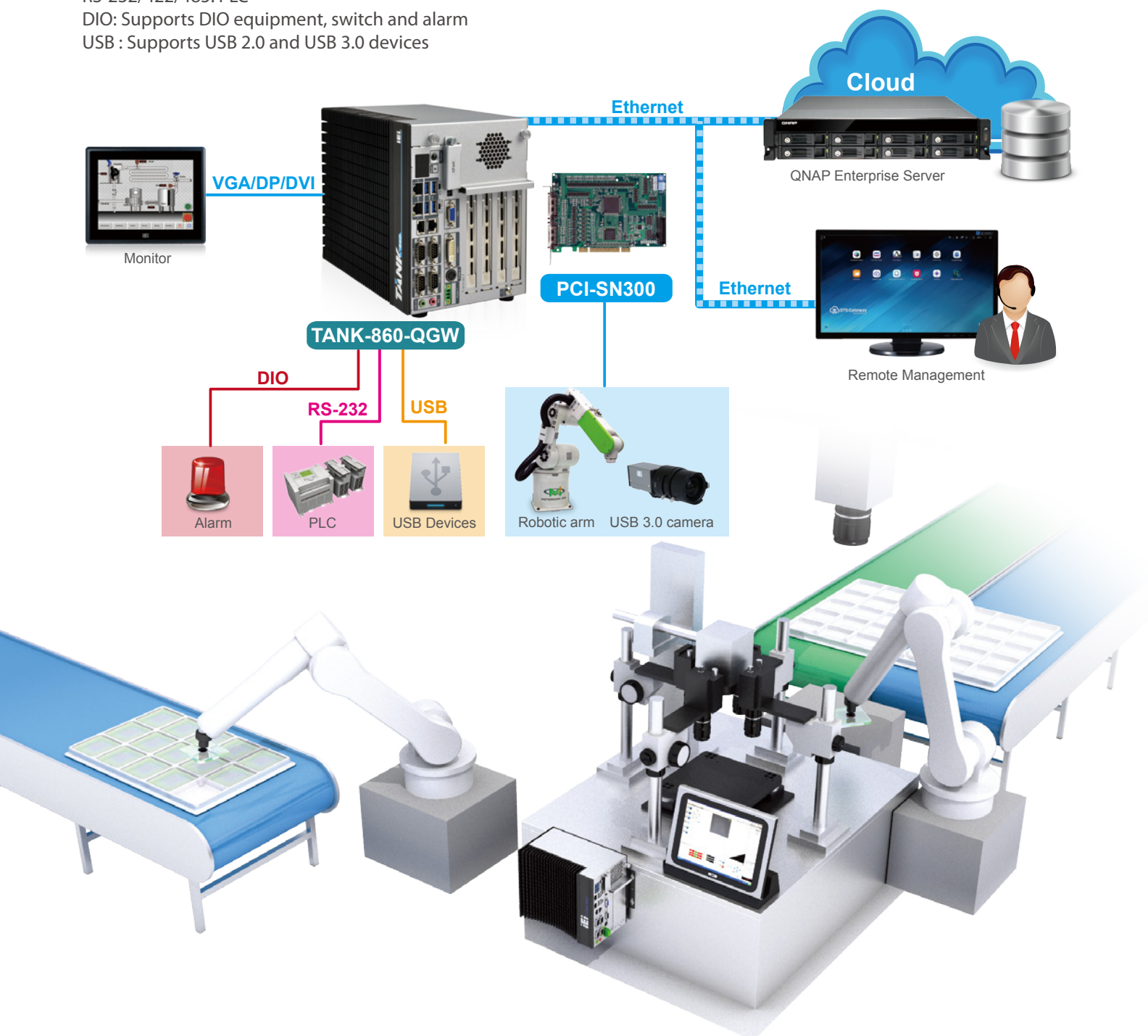

Hardware Specifications



TANK-860-QGW-i5/8G/2A



TANK-860-QGW-i5/8G/6A



TANK-860-QGW-i5/8G/4A

Model Name		TANK-860-QGW	
Chassis	Color	Black + silver	
	Dimensions (WxDxH)	2 slots:121.5 x 255.2 x 205 4 slots:154.8 x 255.2 x 205 6 slots:195.4 x 255.2 x 205	
	Fan	Fanless	
	Material	Die-casting aluminum	
Mainboard	CPU	Intel® 4th Gen Core™ i5-4400E 2.7GHz, 37W	
	Chipset	Intel® HM86	
	Memory	2 x 204-pin DDR3 SO-DIMM preinstalled two 4 GB (Maximum memory size supported by the system is 16 GB)	
IPMI	iRIS solution	iRIS-2400 (optional purchase)	
Storage	HDD	2 x 2.5" SATA 6Gb/s HDD/SSD Bay	
	CFast	1 x CFast	
I/O interface	USB 3.0	4	
	USB 2.0	2	
	Network port	2 x RJ-45 1 x PCIe GbE by Intel I210 1 x PCIe GbE by Intel I217LM	
	Serial port	4 x RS-232 (DB-9, two with isolation) 2 x RS-422/485 (RJ-45)	
	Digital I/O	8-bit digital I/O, 4-bit input/4-bit output	
	Video output	1 x VGA, 1 x DVI-I, 1 x DisplayPort	
	Resolution	VGA: Up to 1920 x 1200@60Hz DVI-I: Up to 2500x 1600@60Hz DisplayPort: Up to 2500x 1600@60Hz	
	Audio	1 x VGA, 1 x DVI-I, 1 x DisplayPort	
	Expansion slot	PCI/PCIe	2 slots: 2 * PCIe x8 (physical PCIe x16 slot) 4 slots: 2 * PCIe x8 (physical PCIe x16 slot) + 2 * PCI 6 slots: 1 * PCIe x8 (physical PCIe x16 slot) + 2 * PCIe x4 + 3 * PCI
		PCIe Mini	4 slots: 1 x Full-size (baseboard) 6 slots: 1 x Full-size (baseboard)
Power	Power input	DC Jack : 9~36V DC	
	Power consumption	19V @ 3.34A (Intel® Core™ i5-4400E with 4 GB memory)	
Stability	Installation	Upright/wall-mounted	
	Operating temperature	Ventilated environment -20 ~60° C (SSD), Non-condensing environment 5% ~ 95%	
	Storage temperature	Ventilated environment -30° C ~70° C (SSD), Non-condensing environment 5% ~ 90%	
	Impact test	Half-sine wave shock 5G; 11ms; 3 shocks per axis	
	Vibration test	MIL-STD-810F 514.5C-2 (with SSD)	
	Net weight/gross weight	2 slots: 4.2 kg/6.3 kg 4 slots: 4.5 kg/6.5 kg 6 slots: 4.8 kg/6.9 kg	
	Safety standard	CE/FCC	

I/O interface

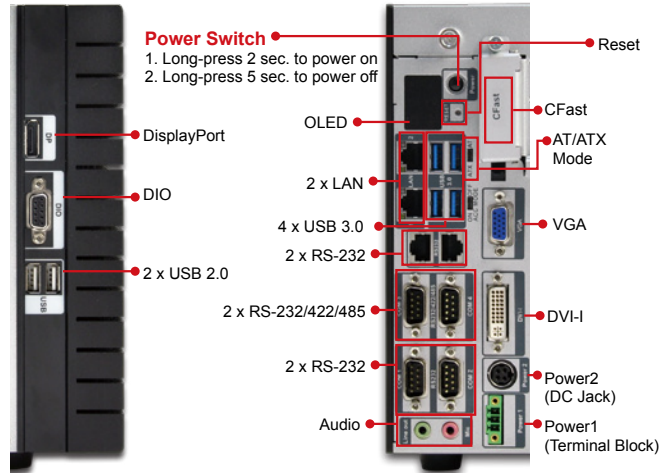

Ordering information

Part No.	Description
TANK-860-QGW-i5/8G/2A-R10	Intel® Core™ i5-4400E processor, two 4 GB DDR3 memory, two PCIe expansion slots, network port, serial port, digital I/O, VGA/DVI-I/DisplayPort, optional iRIS-2400, built-in QTS-Gateway, 9V~36V DC, RoHS
TANK-860-QGW-i5/8G/4A-R10	Intel® Core™ i5-4400E processor, two 4 GB DDR3 memory, two PCIe and two PCI expansion slots, network port, serial port, digital I/O, VGA/DVI-I/DisplayPort, optional iRIS-2400, built-in QTS-Gateway, 9V~36V DC, RoHS
TANK-860-QGW-i5/8G/6A-R10	Intel® Core™ i5-4400E processor, preloaded 2 x 4GB DDR3 memory, 3 x PCIe + 3 x PCI expansion slot, network port, serial port, digital interface, VGA/DVI-I/DisplayPort, optional purchase iRIS-2400, preloaded QTS-Gateway, 9V~36V DC, RoHS

Packing list

Packing list	
1 x	Installation CD
1 x	Chassis screw set
1 x	Installation frame set

Optional accessory

Part No.	Description
32000-000002-RS	European regulatory power cord
32000-089900-RS	European regulatory power cord
63040-010120-210-RS	Power supply, input voltage: 90~264VAC, 120W, output voltage:19V DC, 4-pin attachment connector, CCL, RoHS
19Z00-000605-00-RS	System fan, +12V DC, 4-pin, 40 mm x 40 mm x10 mm, 6500RPM, RoHS
iRIS-2400-R10	IPMI 2.0 expansion card, DDR3 SO-DIMM slot

Software Specifications

Operating System

- QTS 4.2 (embedded Linux)

Supported Client OS

- Windows 7, Windows 8, Windows 10, Windows Server 2003/2008 R2/2012/2012R2
- Apple Mac OS X
- Linux & UNIX

Supported Browsers

- Microsoft Internet Explorer 10+
- Google Chrome
- Apple Safari 7+
- Mozilla Firefox

Multilingual Support

- Chinese (Traditional & Simplified), Czech, Danish, Dutch, English, Finnish, French, German, Greek, Hungarian, Italian, Japanese, Korean, Norwegian, Polish, Portuguese (Brazil), Romanian, Russian, Spanish, Swedish, Thai, Turkish

File System

- Internal Hard Drive: EXT4
- External Hard Drive: EXT3, EXT4, NTFS, FAT32, HFS+

Networking

- TCP/IP (IPv4 & IPv6: Dual Stack)1
- Quad Gigabit NICs with jumbo frame (failover, multi-IP settings, port trunking/NIC teaming)
- Service binding based on network interfaces
- Squid Proxy server
- Proxy client
- DHCP client, DHCP server
- Protocols: CIFS/SMB, AFP (v3.3), NFS(v3), FTP, FTPS, SFTP, TFTP, HTTP(S), Telnet, SSH, SNMP, SMTP, and SMTPS
- UPnP & Bonjour Discovery
- USB Wi-Fi Adapter Support**

Network & Virtual Switch

- TCP/IP (IPv4 & IPv6: Dual Stack)1
- Quad Gigabit NICs with jumbo frame (failover, multi-IP settings, port trunking/NIC teaming)
- DHCP client, DHCP server
- USB Wi-Fi Adapter Support**
- Virtual Switch

Security

- Network access protection with auto-blocking: SSH, Telnet, HTTP(S), FTP, CIFS/SMB, AFP
- CIFS host access control for shared folders
- FIPS 140-2 validated AES 256-bit volume-based and shared folder data encryption2
- AES 256-bit external drive encryption2
- Importable SSL certificates
- Instant alerts via email, SMS, beep, push service, and LCD panel3
- 2-step verification

Storage Management

- Storage Space Utilization monitoring
- QNAP flexible Volume/LUN with thin provisioning and space reclaim3
- Disk volume types
- 2-Bay: RAID 0, 1, single
- Supports storage pools3
- Supports snapshots (4GB System RAM required)3
- Supports Volume/LUN snapshot
- Snapshot manager
- Snapshot clone
- Snapshot vault
- Snapshot replica
- Snapshot agent for Microsoft Windows and VMware vSphere
- Online RAID capacity expansion and online RAID level migration
- SMART data migration
- Bad block scan and hard drive S.M.A.R.T.
- Bad block recovery & RAID recovery
- Bitmap support

Power Management

- Wake on LAN
- Internal hard drive standby mode
- Scheduled power on/off
- Automatic power on after power recovery
- USB and network UPS support with SNMP management
- System sleep mode (S3)3

Access Right Management

- Batch users creation
- Import/Export users
- User quota management
- Local user access control for CIFS, AFP, FTP, and WebDAV
- Application access control for Photo Station, Music Station, Video Station, and File Station
- Subfolder permissions support for CIFS/SMB, AFP, FTP, and File Station

Domain Authentication Integration

- Microsoft Active Directory (AD) & Domain Controller support
- LDAP server, LDAP client
- Domain users login via CIFS/SMB, AFP, FTP, and File Station

myQNAPcloud Service

- Private cloud storage and sharing
- Free host name registration (DDNS)
- Auto router configuration (via UPnP)
- Web-based file manager with HTTPS 2048-bit encryption
- CloudLink for remote access without any complicated router setup
- myQNAPcloud connect for easy VPN connection (Windows VPN utility)

Qsync

- Sync files across multiple devices with SSL secure connection
- Selective synchronization for only syncing specific folders
- Use team folders as a file center for greater team collaboration (maximum sync tasks: x8632, ARM:5)
- Shares files by links via e-mail
- Policy settings for conflicting files and file type filter support
- Version control: up to 64 versions.
- Unified privilege management
- Unified configuration management
- Supports central configuration mode
- Supports remote erase/restore
- Supports shared folders sync
- Supports Windows & Mac OS

Web Administration

- Multi-window, multi-tasking based system management
- Smart toolbar and dashboard for neat system status display
- Dynamic DNS (DDNS)
- SNMP (v2 & v3)
- Resource monitor
- Network recycle bin for file deletion via CIFS/SMB, AFP, and File Station
- Automatic Cleanup
- File Type Filter
- Comprehensive logs (events & connection)
- Syslog client/server
- System settings backup and restore
- Mobile app: Qmanager for remote system monitoring & management

File Server

- File sharing across Windows, Mac, and Linux/UNIX
- Microsoft networking
- Windows ACL
- Advanced folder permissions for CIFS/SMB, AFP, FTP
- Shared folder aggregation (CIFS/SMB)

FTP Server

- FTP over SSL/TLS (Explicit)
- FXP support

File Station

- Supports mounting cloud drives (such as Google Drive, Dropbox, Microsoft OneDrive, Amazon Cloud Drive, Yandex Disk and Box).
- Supports mounting remote shared folders through FTP, WebDAV or Microsoft networking (SMB/CIFS)
- Supports opening documents via Office Online, Google Docs or Chrome Extension (Edit Office files in Google Docs, Sheets, and Slides)
- Supports ISO Mounting (Up to 256 ISO Files)
- Supports sharing download links and upload links
- Drag-n-drop Files via Chrome and Firefox Browsers
- Photo, music, and video preview and playback with hardware-accelerated transcoding3
- File Compression (ZIP or 7z)
- Creation of and sending download links for sharing public files with expiration date and password protection
- Supports displaying subtitles (*.SRT, UTF-8 format)
- Video seeking support for video playback during on-the-fly transcoding3
- Supports slideshow playback in media viewer
- Mobile App: Qfile for file browsing and management

Backup Station

- Remote replication server (over rsync)
- Real-time remote replication (RTRR) to another QNAP NAS, FTP or CIFS/SMB server
- Works as both RTRR server & client with bandwidth control
- Real-time & scheduled backup
- Backup versioning for RTRR
- Snapshot support for RTRR/rsync
- Encryption, compression, file filter, and transfer rate limitation
- Desktop backup with QNAP NetBak Replicator for Windows
- Apple Time Machine backup support
- Data backup to multiple external storage devices
- Third party backup software support: Veeam backup & replication, Acronis True Image, Arcserve backup, emc retrospect, Symantec Backup Exec, etc.

Cloud Drive Sync

- Multiple cloud account management like Google Drive, Dropbox, OneDrive, and hubic
- Supports multiple cloud accounts
- Manual, scheduled, periodic and continuous sync
- Flexible file filtering using type, date, and size
- SSL transfer encryption
- Dashboard and job statistics
- Configurable network error recovery options
- Extensive job activity logging for tracing history of status and statistics
- Concurrent job execution and multi-threaded data transfer
- Per-account bandwidth throttling

Cloud Backup Station

- S3 Plus (including Amazon S3)
- Amazon Glacier
- Google Cloud Storage
- WebDAV-based cloud storage
- Microsoft Azure
- OpenStack Swift

Print Server

- Max number of printers: 3
- Supports Internet Printing Protocol
- Print job display and management
- IP-based and domain name-based privilege control

HD (HybridDesk) Station

- Playback videos, music, photos on TV with Kodi via HDMI
- Watch various online content such as YouTube, Flickr, Picasa, Shoutcast, etc.
- Web browsers (Chrome, Firefox)
- Supports international keyboards, input and mouse
- Supports QNAP Qremote app and the official Kodi remote app
- Supports user login permissions

Note:

The playback and quality of some video files may be affected by the system's CPU and GPU decoding abilities.

Linux Station

- Support install the Ubuntu OS via Linux Station. Use your device as a Ubuntu PC using the video output.
- Download and use a variety of applications from the Ubuntu Software Center.
- Supports remote desktop to monitor and access Ubuntu remotely.
- An open source software platform for developers.

Note:

Requires at least 4GB RAM and Container Station must be installed.

Virtualization Station

- Supports Virtual Machine (VM) creation to run operating systems such as Windows, Linux, Unix and Android
- Supports VM import and export
- Supports VM cloning & snapshots
- Supports VM backup and restore
- VM console can be displayed via HDMI output - QVM
- HTML5-based shared remote console
- Supports three different networking modes: Isolated, External-only and Bridged

Container Station

- Supports LXC and Docker
- Download applications from the built-in Docker Hub Registry
- Supports one-click installation, container export/import & console mode
- Supports two network modes (NAT and host)
- Supports auto-start containers
- Supports downloading Docker certificates
- Supports adding private registries
- Added an application repository for users to switch to any repository on GitHub.com.

Q'center (NAS CMS)

- Multiple NAS monitoring
- Utilization history reports
- Unified configuration management
- Visual display reports
- Monitor NAS behind NAT routers with Q'center Assistant
- Virtual appliances supported with Microsoft Hyper-V and VMware ESXi

Surveillance Station

- Supports over 3,000 IP cameras
- Includes 4 free camera licenses, up to 40 camera channels by purchasing additional licenses3
- Instant playback to check recent events
- Visual aid by e-map
- Playback and speed control using the shuttle bar
- Video preview on playback timeline
- Intelligent video analytics (IVA) for advanced video searching
- Surveillance client for Mac
- Mobile surveillance app: Vmobile (iOS and Android)
- Mobile recording app: Vcam (iOS and Android)

VPN Server

- Secure remote access: PPTP · L2TP/IPsec & OpenVPN VPN services
- Max number of clients: 45

VPN Client

- Supported VPN protocols: PPTP and OpenVPN services
- PPTP Authentication: PAP, CHAP, MS-CHAP, MS-CHAPv2
- PPTP Encryption: None, AES 40/128 bit, AES 256 bit
- OpenVPN Encryption: None, AES 40/128 bit, AES 256 bit
- Transmission package monitor
- OpenVPN port control
- OpenVPN link connection

DLNA Server

- Supports DLNA/UPnP TVs and players such as PlayStation 4 and Xbox One
- Support CUE indexing file for APE, FLAC audio format.
- Video and Audio On-the-fly Transcoding3

App Center

- Over 100 official and community software add-ons

- 1 Not all IPv6 services are supported.
- 2 Data encryption functions may be unavailable in accordance with the legislative restrictions of some countries.
- 3 This feature may vary by model.
- 4 DRM-protected content is not supported.

Designs and specifications are subject to change without notice.



Built-in QTS Gateway
Few clicks to start a cloud

• TANK-860-QGW-i5/8G/2A • TANK-860-QGW-i5/8G/4A • TANK-860-QGW-i5/8G/6A

- ✓ Physical to virtual; painless migration with zero threshold
- ✓ Lightweight virtual application Container, best partner for IoT operation and maintenance
- ✓ Plug and play open source Linux Station with VGA, DVI, and Display Port



Headquarters
威強電工業電腦 IEI Integration Corp.
No. 29, Zhongxing Rd., Xizhi Dist., New Taipei City 221, Taiwan
TEL : +886-2-86916798 / +886-2-26902098 FAX : +886-2-66160028
sales@ieiworld.com www.ieiworld.com

America
IEI Technology USA Corp.
138 University Parkway, Pomona, CA 91768
TEL : +1-909-595-2819 FAX : +1-909-595-2816
sales@usa.ieiworld.com usa.ieiworld.com

China
威強電工業電腦 IEI Integration (Shanghai) Corp.
上海市闵行区莘庄工业区申富路515号
515, Shen Fu Rd., Xin Zhuang Industrial Develop Zone, Shanghai, 201108, China
TEL: +86-21-3116-7799 FAX: +86-21-3462-7797
sales@ieiworld.com.cn www.ieiworld.com.cn